

MANHATTAN

CORDLESS TABLE LAMP



DESIGNED & ASSEMBLED
IN AUSTRALIA



5 YEARS
WARRANTY



95+ CRI
LED



ALL PARTS
REPLACEABLE



INTERNATIONAL
DELIVERY



NEW
Natural
Solid Brass with
Cotton Shade



NEW
Natural
Solid Brass with
Pleated Silk Shade



NEW
Natural
Solid Brass with
Frosted Glass Shade



NEW
Natural
Solid Brass with
Amber Glass Shade



NEW
Natural
Solid Brass with
Green Glass Shade



NEW
Natural
Solid Brass with
No Shade

MANHATTAN - Technical Description

Inspired by the art-deco skyscrapers of the cultural and financial hub, the Manhattan cordless lamp showcases a dynamic and elegant design. The vertical lines and stepped forms evoke the glamour and optimism of the Machine Age.

The body of the Manhattan is CNC milled from solid brass. The mirror polished surface is left unlacquered and with time will develop a golden patina, bringing out an organic quality with unique colour and texture variation.

Designer	Gabriel Tam
Year of Design	2023
IP Rating	IP30 (Fabric) IP52 (Glass)
Weight	0.80 kg / 1.75 lb (Fabric) 0.85kg / 1.87 lb (Glass)
Approvals & Standards	CE, CSA, C-Tick, FCC, RoHS, SASO
EU Energy Regulation	Exempt - LED lamps operate on batteries

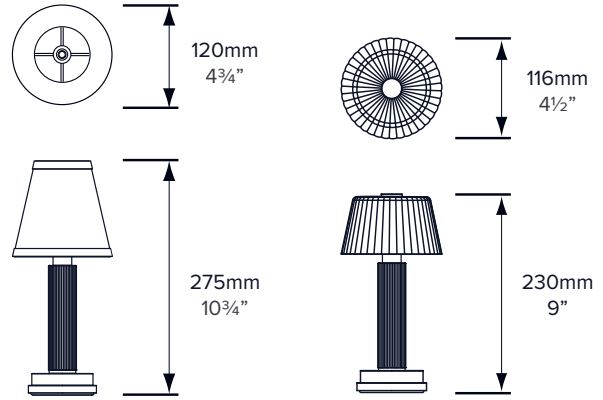







Lamp Control Unit Options

Type	Battery	Cells	Charge Time	Light Source Option	Colour Temperature (Kelvin)	Operating Time (hours)			Brightness (lumens)	CRI*	Bulb Life (Hours)
						High	Med	Low			
UNO	Panasonic Li-ion 3.7V 2900mAh 500+ cycles	1	5.5hrs	1W LED Warm White (Standard)	2600k	13	35	130	68+	95+	50,000+
				1W LED Warm Candle White (Optional)	1800k	13	35	130	58+	93+	50,000+

COLOUR RENDERING INDEX (CRI) The quantitative measure of the ability of a light source to reproduce the colors of various objects faithfully in comparison with an ideal or natural light source. The highest possible CRI is 100.

POWER SOURCE 100 - 240V Switch-Mode Electronic Power Supply
Approved for worldwide usage supplied with appropriate mains electric plug type

Recharging Options

					
Single Lamp Charger 1 Lamp	Small Recharging Tray 4 Lamps	Large Recharging Tray 12 Lamps	Small Recharging Station 24 Lamps	Medium Recharging Station 36 Lamps	Large Recharging Station 48 Lamps